

New products I/2025

# Die making



AVAILABLE  
IMMEDIATELY



## Strip stop

- › For precise stamping on the first stroke
- › Easy positioning of the strip
- › Automatic deactivation on the first stroke

[www.meusburger.com](http://www.meusburger.com)

# Strip stop

Our new strip stop is equipped with a spring-loaded release function and enables fast and precise positioning of the material strip. Thanks to its innovative design, it is easy and convenient to operate and thus enables precise stamping on the first stroke. Efficient and error-free stamping processes are guaranteed.

## How you benefit

- › For precise stamping on the first stroke
- › Simple operation thanks to quick and convenient activation
- › Automatic deactivation on the first stroke
- › Can be used on both sides, small installation space

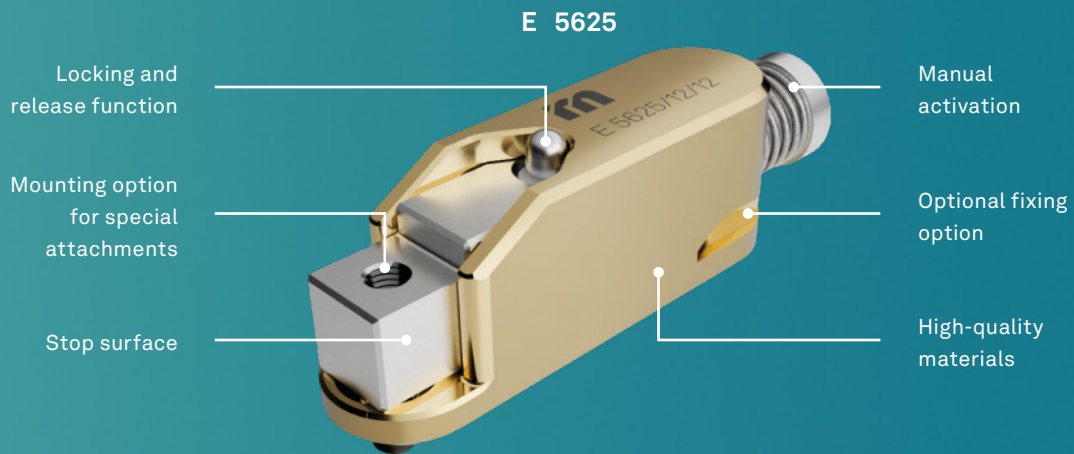

When the strip stop is locked, the strip is pushed into the correct position. The stamping process can now begin.

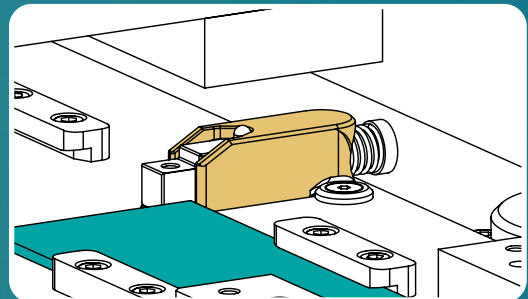

Thanks to the integrated release function, the spring-loaded strip stop is deactivated by the upper part and moves out of the active area.

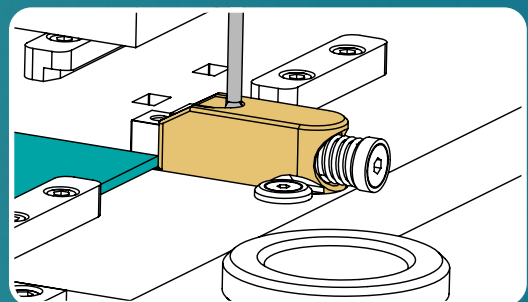

NE – Blocks for eroding

## New thicknesses for our blocks for eroding

Available in

- › Tool steel
- › Powder metallurgical steel
- › Carbide

How you benefit

- › Common dimensions, heat-treated or hardened, tempered at least 3 times
- › Deep-frozen if required by the material
- › Rolling direction indicated
- › 100% availability

VARIOUS  
MATERIALS



Guiding

EXPANDED

## Guide pillars

Our guide pillars impress with their high precision and durability. As of now, our classic pillars are available in additional lengths.

- › Maximum precision through tolerance class h3
- › Suitable for sliding and bearing guides
- › All dimensions available from stock

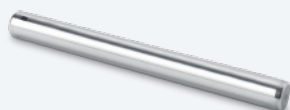

**E 5028**

ø = 4–19

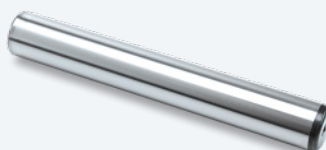

**E 5030**

ø = 19–63

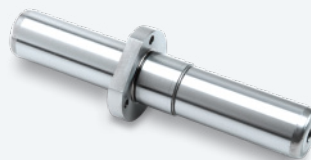

**E 5080**

ø = 20–50

## Configurator for customising guide pillars

Discover our new configurator for special dimensions of guide pillars. Adjust your pillars individually to your needs – quickly, easily and precisely. Get started now and experience the flexibility of our customised solutions!

Available for: E 5000, E 5010, E 5028, E 5030, E 5076, E 5078, E 5080



Try out the new configurator right away:

[www.meusburger.com/configurator-guide-pillars](http://www.meusburger.com/configurator-guide-pillars)

## Die sets

# ST – Die set for table presses

The die set serves as a stable base for assembly, stamping and pressing processes. Our die set for table presses features a robust design that ensures absolute stability, thereby guaranteeing precise and reliable work. It is very versatile, so it can be adapted to various table presses, making it ideal for a wide range of applications in production or in workshops.

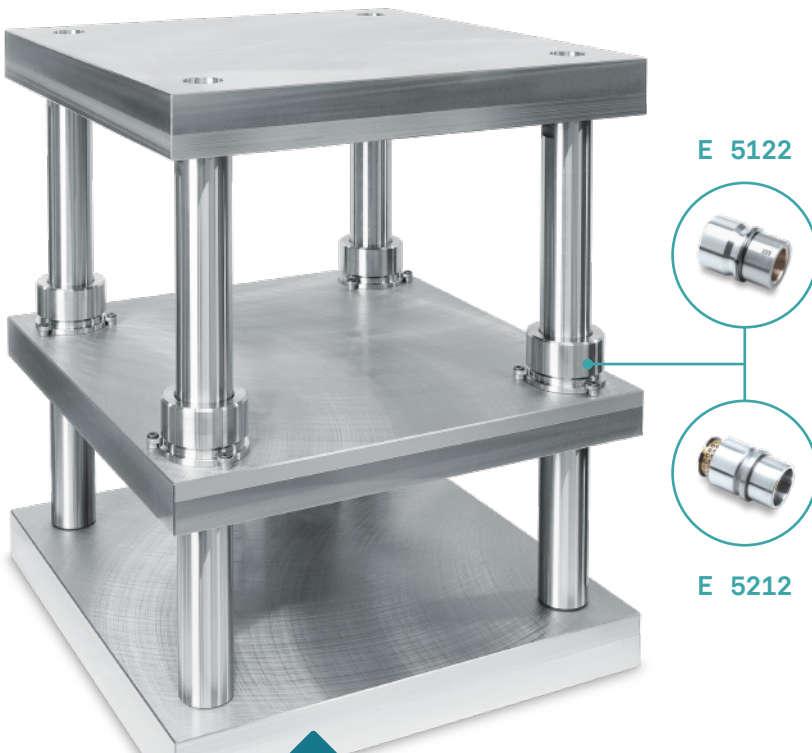

### Available sizes:

- › 346 x 346 mm / stroke: 315 mm
- › 496 x 496 mm / stroke: 400 mm



THOMAS

ENZ

### Technology management Die making

*In response to numerous customer requests, we have developed a standardised die set for table presses, which is used as a base die set for testing, prototyping, experimental setups and simple assembly activities. The customers can choose how to control the die set: hydraulically, pneumatically, or electrically.*

## Guiding

# New sizes for the limiting bush E 5258

Thanks to the adjustment of our limiting bush, one size can now be used for two different pillar diameters.

- › Prevents cage movements
- › Adapted inner diameter prevents slipping during installation



E 5258

## Block-shaped strip lifter E 5643

Thanks to its large, unilateral infeed chamfer, the new block-shaped, spring-loaded strip lifter enables an easy insertion of the strip into the die. It is very compact, so it can also be used as a lifter with a stroke of up to 6 mm within the die.

### How you benefit

- › Easy installation from the working plane
- › Low space requirement thanks to stop via shoulder screw
- › Withdrawal thread for easy removal



E 5643

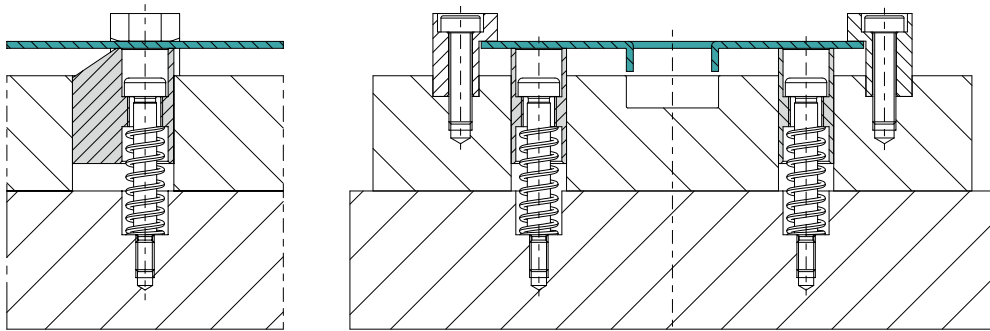

## Spring cover E 1549

- › For easy spring replacement
- › Through hole and spring cover instead of laborious threading of a blind hole for spring installation
- › Matched to the diameters of the system compression springs



E 1549

∅ 16 MM  
&  
∅ 50 MM

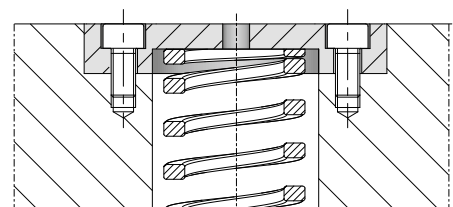

# Experience the magic of the portal

Enter the magical world of the new Meusburger portal.



## Discover your advantages

With a whole lot of new functions, the portal offers you numerous ways to reach your goals blazingly fast – and all this 24/7 in up to 20 languages. Experience the magic of the portal, where designing is astonishingly easy and a fantastic all-round service awaits you!

- › Blazingly fast to the goals
- › Astonishingly easy designing
- › Fantastic all-round service

**Experience the magic!**  
[www.meusburger.com/portal-en](http://www.meusburger.com/portal-en)



## New portal features

### Wizards for die sets

The new wizards make it very easy for you to assemble your die set according to your desires. They combine the tried and trusted advantages with optimised and clearer functions.

Your benefits compared to the former wizards:

- › Items can be added directly to a parts list.
- › Items can be added directly to the shopping cart.
- › CAD data can be exported immediately.

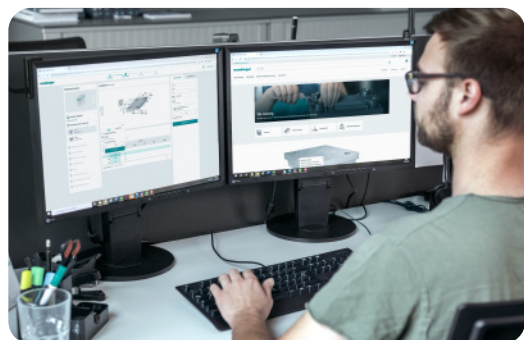

**++  
+** Try out the new wizards right away:

[www.meusburger.com/die-set-wizards](http://www.meusburger.com/die-set-wizards)